

Cuisinart®

INSTRUCTION BOOKLET



Grind & Brew™ 12-Cup Automatic Coffeemaker

DGB-625 Series

For your safety and continued enjoyment of this product, always read the instruction book carefully before using.

IMPORTANT SAFEGUARDS

When using electrical appliances, basic safety precautions should always be followed to reduce the risk of fire, electric shock and/or injury to persons, including the following:

- 1. READ ALL INSTRUCTIONS.**
2. Do not touch hot surfaces. Use handles and knobs.
3. To protect against electric shock, do not place cord, plug, or base unit in water or other liquids.
4. This appliance should not be used by or near children or individuals with certain disabilities.
5. Always unplug from outlet when not in use and before cleaning. Allow to cool before putting on or taking off parts and before cleaning the appliance.
6. Do not operate any appliance with a damaged cord or plug or after the appliance malfunctions or has been dropped or damaged in any manner. Return appliance to the nearest Cuisinart Repair Center for examination, repair, and electrical or mechanical adjustment.
7. The use of accessory attachments not recommended by Cuisinart may cause injuries.
8. Do not use outdoors.
9. Do not let cord hang over edge of table or counter, or touch hot surface.
10. Do not place on or near a hot gas or electric burner, or in a heated oven.
11. Always fill water reservoir first, then plug cord into the wall outlet. To disconnect, push the Off button, then remove plug from wall outlet.
12. Do not use appliance for other than intended use.
13. Snap lid securely onto carafe before serving any beverages.
14. Scalding may occur if the lid is removed during the brewing cycle.

15. The glass carafe is designed for use with this appliance only. It must never be used on the range top.
16. Do not set a hot carafe on a wet or cold surface.
17. Do not use a cracked carafe or a carafe having a loose or weakened handle.
18. Do not clean carafe or warming plate with cleansers, steel wool pads, or other abrasive materials.
- 19. WARNING: TO REDUCE THE RISK OF FIRE OR ELECTRIC SHOCK, DO NOT REMOVE THE BASE PANEL. NO USER SERVICEABLE PARTS ARE INSIDE. REPAIR SHOULD BE DONE ONLY BY AUTHORIZED PERSONNEL.**
20. Avoid contact with moving parts.
21. Check grinder basket for presence of foreign objects before using.
22. Use the coffee grinder to grind roasted coffee beans only. Grinding other substances, such as nuts, spices or unroasted beans, may dull the blade and cause poor grinding or injury.
23. Do not place cloth or otherwise restrict airflow beneath coffeemaker.
24. Use only the Cuisinart® Gold Tone Commercial Style Filter or standard #4 basket paper filter with this unit. OTHER GOLD TONE PERMANENT FILTERS MAY CAUSE THE COFFEEMAKER TO OVERFLOW.

SAVE THESE INSTRUCTIONS FOR HOUSEHOLD USE ONLY

WARNING: RISK OF FIRE OR ELECTRIC SHOCK



The lightning flash with arrowhead symbol within an equilateral triangle is intended to alert the user to the presence of uninsulated dangerous voltage within the product's enclosure that may be of sufficient magnitude to constitute a risk of fire or electric shock to persons.



The exclamation point within an equilateral triangle is intended to alert the user to the presence of important operating and maintenance (servicing) instructions in the literature accompanying the appliance.

SPECIAL CORD SET INSTRUCTIONS

A short power-supply cord is provided to reduce the risks resulting from becoming entangled in or tripping over a longer cord. Longer extension cords are available and may be used if care is exercised in their use.

If a long extension cord is used, the marked electrical rating of the extension cord must be at least as great as the electrical rating of the appliance, and the longer cord should be arranged so that it will not drape over the countertop or tabletop where it can be pulled on by children or tripped over.

NOTICE

This appliance has a polarized plug (one blade is wider than the other). To reduce the risk of electric shock, this plug will fit into a polarized outlet only one way. If the plug does not fit fully into the outlet, reverse the plug. If it still does not fit, contact a qualified electrician. Do not modify the plug in any way.

OPERATING NOTICE

Clogging and backing up of water and/or coffee in the filter basket can occur under any or a combination of any of the following conditions: The use of too finely ground coffee, using two or more paper filters, using the gold tone filter in conjunction with a paper filter or not properly cleaning coffee grounds from the gold tone filter, or allowing coffee grounds to spill over the filter.

Caution: Never open the filter basket during the brewing cycle, even if no water is draining from the filter basket, since extremely hot water/coffee can spill out from the filter basket and cause injury. If water/coffee is not draining from the filter basket during the brewing cycle, unplug the unit and wait 10 minutes before opening and checking the filter basket.

	WARNING RISK OF FIRE OR ELECTRIC SHOCK DO NOT OPEN	
WARNING: TO REDUCE THE RISK OF FIRE OR ELECTRIC SHOCK, DO NOT REMOVE COVER (OR BACK) NO USER-SERVICEABLE PARTS INSIDE REPAIR SHOULD BE DONE BY AUTHORIZED SERVICE PERSONNEL ONLY		

CONTENTS

Important Safeguards.	2-3
Important Unpacking Instructions	4
The Quest for the Perfect Cup of Coffee.	4
Features and Benefits	5
Control Panel	6
Programming Your Coffeemaker	7
Setting the Program Time	7
Before Brewing your First Pot	8
Making Coffee with Whole Beans	8
Making Coffee with Pre-Ground Beans	9
Charcoal Water Filter	9
Brew Pause™ Feature.	10
Cleaning and Maintenance	10
Warranty	11

IMPORTANT UNPACKING INSTRUCTIONS

1. Place the box on a large, sturdy, flat surface.
2. Remove the instruction book and any other literature.
3. Turn the box so that the backside of the coffeemaker is down and slide the coffeemaker from the box.
4. After the coffeemaker has been removed, place the box out of the way and lift off the packing material.
5. Grasp the carafe by its handle, remove it from the warming plate and remove the polybag.
6. Remove the polybag covering the coffeemaker.

Save all packing materials in case you have to ship the machine in the future. **KEEP ALL PLASTIC BAGS AWAY FROM CHILDREN.**

THE QUEST FOR THE PERFECT CUP OF COFFEE

Element 1: Water

Coffee is 98% water. The quality of that water is as important as the quality of your coffee. If water doesn't taste good from the tap, it won't taste good in your coffee. Cuisinart includes a charcoal water filter to remove chlorine, bad tastes and odors, for the purest coffee flavor, every time you brew.

Element 2: Coffee

While coffee is 98% water, all of the flavor comes from the beans. To achieve the same great taste you enjoy at a coffee bar, buy only a two-week supply of fresh coffee beans at a time. Once the bean is broken, its flavor degrades quickly. That's why Cuisinart grinds your beans just prior to brewing.

Element 3: Grind

The grind is critical for proper flavor extraction. If the grind is too fine, overextraction and bitterness will result. Too fine a grind may also clog the filter. If grind is too coarse, the water will pass through too quickly and the maximum flavor will not be extracted. Your coffeemaker is preset for medium, the optimal grind for this type of brewing process.

Element 4: Proportion

Coffee that is too strong or too weak is always a disappointment. Follow the recommended portions of whole beans or ground coffee in the instructions under MAKING COFFEE, and later adjust the amount to your taste.

DO NOT OVERFILL OR THE GRINDER COULD MALFUNCTION AND/OR THE COFFEEMAKER COULD OVERFLOW.

FEATURES AND BENEFITS

1. Reservoir Cover with Release Button

Flips back for easy filling. Removable for easy cleaning. A safety interlock system prevents operation of the unit if the reservoir cover is open.

2. Showerhead (not shown)

Distributes water evenly over coffee, reducing temperature loss as water passes through grounds.

3. Control Panel

See detailed drawing, page 6.

4. Filter Basket Compartment

See detailed drawing, page 6.

Contains: Filter Basket, Filter Basket Cover, Cuisinart Gold Tone Commercial Style Filter

5. Filter Basket Door

6. Filter Basket Door Release Button (not shown)

7. Brew Pause

Stops flow of coffee from basket when carafe is removed from warming plate so a cup can be poured in mid-brew, if desired.

8. Warming Plate

Scratch-resistant with nonstick coating.

9. Carafe

The easy-pour, dripless 12-cup carafe has an ergonomic handle and brewed coffee markings for two to twelve cups.

10. Cord Storage (not shown)

11. Measuring Scoop and Brush (not shown)

12. #4 Basket Paper Filters included (not shown)

13. Water Reservoir with Water Level Indicator

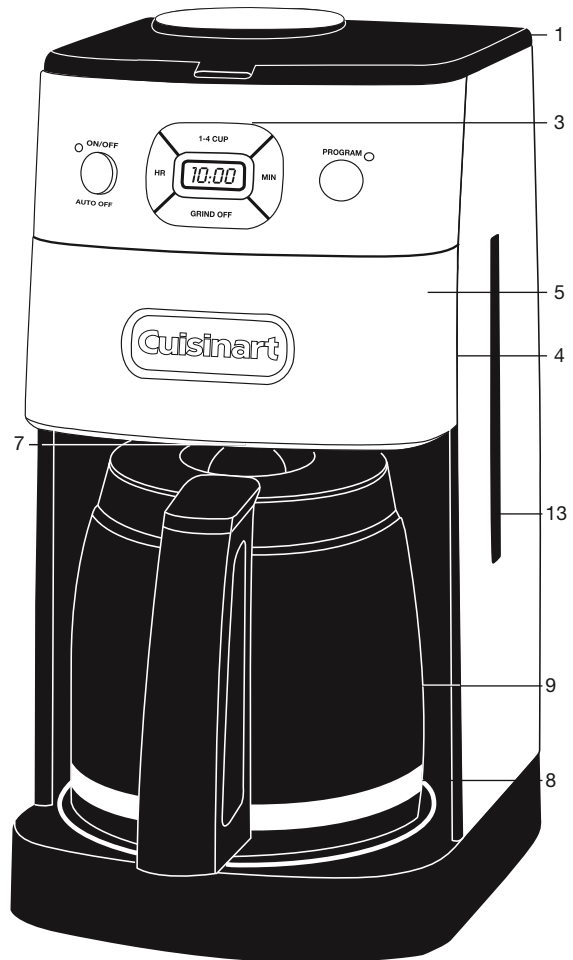

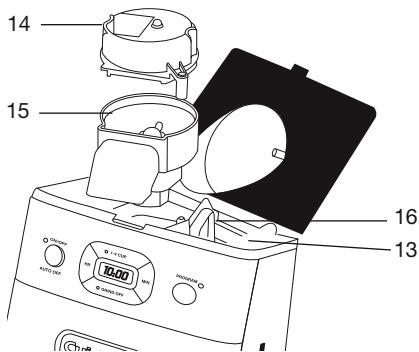

14. Grinder Basket Lid

Use the recess on each side of the lid to remove lid for easy addition of beans.

15. Grinder Basket

16. Charcoal Water Filter

Charcoal water filter eliminates chlorine, bad tastes and odors from tap water.

NOTE: Follow directions for preparing and inserting filter on page 9.

17. Filter Basket Cover

To put on or remove, grasp cover in area indicated by arrows. Cover becomes hot after coffee is brewed. Use caution when removing cover.

18. Gold Tone Commercial Style Filter

A note about filters: When using our permanent filter, position handle toward front of the unit so it does not interfere with the flow of coffee into the filter basket. Also note: using our permanent filter may allow some fine coffee grounds to fall into, and appear as sediment in the carafe.

19. Filter Basket

Holds our commercial style permanent filter or paper filter. **NOTE: FILTER BASKET MUST BE IN PLACE FOR UNIT TO OPERATE CORRECTLY.** Removable for easy cleaning.

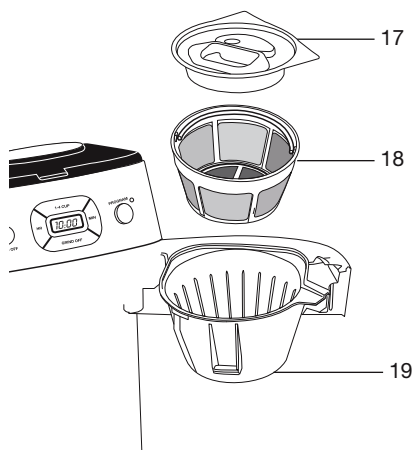

GETTING TO KNOW YOUR CONTROL PANEL

(Detailed programming instructions on page 7.)

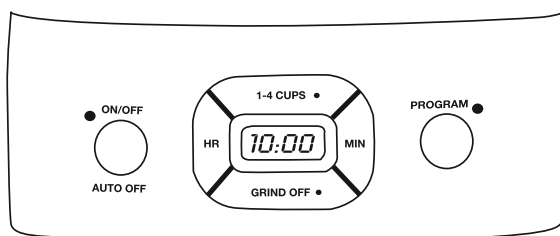

Clock/LCD Display

Displays time of day and Auto On times.

On/Off button with LED Indicator

Manually turns coffeemaker on or off.

Audible Tone (not shown)

An audible tone sounds 5 times when brew cycle is complete.

1-4 Cup Setting

Improves extraction, flavor and temperature when brewing fewer than 5 cups.

Hour and Minute Buttons

Use to program clock and Auto On function.

Grind Off Button with LED Indicator

Turns off the grinder when using pre-ground coffee.

Program Button with LED Indicator

Sets and/or displays programmed Auto On time.

PROGRAMMING YOUR COFFEEMAKER

SETTING THE CLOCK

When the coffeemaker is plugged in, 12:00 will appear until you set the time.

Entering Time Set Mode

Hold down the Hour or Minute button until the clock begins flashing. Press either button to select the desired time. Hold buttons down to scroll through the digits, or press and release to advance one digit at a time. When scrolling, the numbers will advance slowly and then speed up.

When the number displayed approaches the desired time, press and release to advance one digit at a time. Be sure the PM indicator is on if a PM time is desired.

Exiting Set Time Mode

- a. Press any function button besides Hour or Minute to exit mode.
- b. If you do nothing for a period of five seconds the mode will be exited.

SETTING THE PROGRAM TIME

When you press the Program Set button, it displays a previously selected auto-on time, or the default time (12:00pm).

Entering Set Program Time Mode

Press and hold the Program set button until the green light and LCD display begin to flash. You are now in Set Program Time mode. Set the time you want coffee to begin brewing by following the instructions in “Entering Time Set Mode.”

The coffeemaker will start to brew at the programmed time. The Program mode cannot be entered if the coffeemaker is in its brew cycle.

Exiting Set Program Time Mode

- a. Press and release Program button.
- b. Press any function button besides Hour or Minute to exit mode and activate the selected function.
- c. If you do nothing for a period of five seconds the mode will be exited.

SETTING THE AUTO SHUTOFF TIME

The automatic shutoff time (ASO) can be programmed to shut off immediately after brewing (0:00) or up to 4 hours later. The default shutoff time is 2 hours.

Press and hold the On/Off button to display current shutoff time. To change the preset time, press and hold the On/Off button until the red power light and LCD display begin to flash. This signals that you have entered the Set automatic shutoff mode. Set the time you want coffee to begin brewing by following the instructions in “Entering Time Set Mode.”

When the coffeemaker shuts itself off, two tones will sound.

NOTE: Automatic shutoff may be programmed either before or during coffee brewing. If you program the auto shutoff time after brewing is completed the unit will automatically account for elapsed time. For example, if you set the auto shutoff for 40 minutes and 25 minutes have already elapsed, the unit will shut off automatically after 15 minutes (40 minutes minus the 25 elapsed equals 15 minutes).

BEFORE BREWING YOUR FIRST POT OF COFFEE

During the manufacturing process, dust can get trapped in your coffeemaker. We recommend flushing out the system before brewing your first pot of coffee. Simply follow “Making Coffee with Pre-Ground Beans,” page 9. Skip step #1 and be sure to use only water and a paper filter...no coffee!

Once you’ve done that, brew a pot of real coffee and get ready to enjoy Cuisinart at its best!

MAKING COFFEE WITH WHOLE BEANS

Follow instructions in “Before Brewing Your First Pot of Coffee” above.

1. Insert Charcoal Water Filter

Follow directions for the preparation and insertion of the charcoal water filter on page 9.

2. Fill the Water Reservoir

Open the reservoir cover and pour in water, using the water level window indicator to measure the number of cups desired. **NOTE:** Do not exceed the 12-cup line. Doing so could cause carafe to overflow.

3. Add Beans

Lift the grinder basket lid, using the recess on either side. Fill the basket with the desired quantity of beans. **NOTE:** Use 1 level scoop of whole beans per cup. For 1 to 4 cups, use 1½ level scoops per cup. Do not add over 14 scoops. This could cause the grinder to malfunction and/or the coffeemaker to overflow.

4. Insert Coffee Filter

Press the filter basket door release Button to open door.

- Paper Filter – place a #4 basket paper filter in the basket, making sure the filter is completely open and touching the side walls and bottom of basket.
- Cuisinart’s® Commercial Style

Permanent Filter – Be sure the filter handle is facing away from the grinder basket, so it does not interfere with the flow of ground coffee into the filter basket. **NOTE:** Some ground coffee may flow into the carafe.

5. Put Filter Basket Lid in Place and Close Filter Door

6. Close Reservoir Lid

Press down to lock. This coffeemaker is equipped with a safety interlock system, which prevents the unit from operating if the cover is open or the grinder cover is left out. If you try to turn the unit on with the cover open, the unit will beep continuously until the missing parts are installed and you close the lid. If you open the cover during the grinding process, it will beep, the grinder will stop grinding and, if brewing, the brewing will stop. Once the missing parts are in place and the cover is closed, the beeping stops. The brewing process can be restarted by pressing the On button. Restarting the process will not affect coffee results. If you do not want the grinder to come on again, press the Grind Off button before pressing the On button.

7. Put Carafe in Place

Make sure you have replaced the glass carafe in its position on the warming plate.

8. Brewing

To Brew Right Away

- a. Push the 1-4 cup button if you are brewing fewer than 5 cups. **NOTE:** Coffeemakers traditionally produce cooler coffee when brewing small pots because the heater doesn’t have time to warm up. This setting double heats water for piping hot coffee.
- b. Press On/Off button. Red LED will light up and brewing will begin.

To Program Brew Time

- a. To select the time you want coffee to start brewing, press the Program button and hold it. The time displayed

in the window is the programmed start time. To change time, follow “Setting the Program Time” instructions on page 7.

- b. Push the 1-4 cup button if you are brewing fewer than 5 cups.
- c. Press and release Program button. Green LED indicates that the unit is in programmed-start mode and the brew cycle will begin at the time you selected.

9. After Brewing

When brew cycle is complete, five beeps will sound and unit will automatically shut itself off after the 2-hour default time unless you’ve programmed another auto-shutoff time. Coffee will continue to stream from the filter for several seconds.

10. To Serve

Once the coffee has finished brewing, stir it before serving to blend the flavors. The coffee at the bottom of the carafe will be somewhat stronger than the coffee at the top. The warming plate will keep coffee at about 180°-185°F. We recommend transferring coffee to a thermal carafe preheated with hot water, if it is not going to be served within 20 minutes.

TIPS AND HINTS

- If you buy large portions of beans, separate them into one or two week portions and store them in airtight containers in the freezer. Preserve freshness by minimizing exposure to air, light, and moisture. Once beans are removed from the freezer, keep them in a sealed container at room temperature, since damaging condensation can occur when beans move from cold to warmer temperatures.
- Some experts feel freezing dark-roast beans can cause oils to coagulate; others disagree. You’ll have to decide that one for yourself!

MAKING COFFEE WITH PRE-GROUND BEANS

Follow instructions in “Before Brewing Your First Pot of Coffee”, page 8.

1. Fill the Reservoir and Insert Filter

See steps #1 and #3 in “Making Coffee with Whole Beans.”

CHARCOAL WATER FILTER

Your coffeemaker comes with a charcoal water filter that eliminates chlorine, bad tastes and odors from tap water.

Inserting the Water Filter

- Remove the filter from polybag and soak it, fully immersed, in cold tap water for 15 minutes.
- Lift the water filter holder out of the water reservoir (see page 6, #15).
- Press down on the filter compartment and pull toward you to open.
- Place filter into the holder and snap it closed. Be careful – improper placement can tear the filter skin.
- Flush filter by running cold tap water through holes in bottom of compartment for 10 seconds.
- Allow the filter to drain completely.
- Slide the water filter holder back into the channel in the water reservoir, pushing it down to the base of the unit.

NOTE: We recommend changing the water filter every 60 days or after 60 uses, and more often if you have hard water.

Replacement filters can be purchased in stores, by calling Cuisinart customer service, or at www.cuisinart.com.

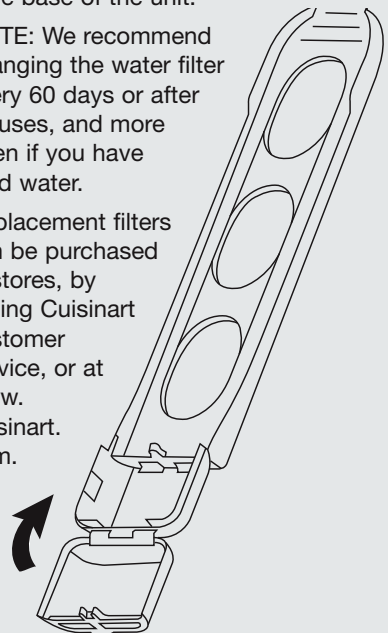

2. Add Pre-Ground Coffee

Our recipe suggestion: Use 1 level scoop of ground coffee per cup. Adjust the recipe according to taste. NOTE: The maximum capacity for ground coffee is 16 level scoops, using either a paper or permanent filter. Exceeding that amount may cause overflow if the coffee is too finely ground.

3. Press Grind Off Button

When this function is activated, an amber LED will come on.

4. Follow steps #4 through #8 in “Making Coffee with Whole Beans.”

Brew Pause™ Feature

Our Brew Pause™ feature interrupts the flow of coffee from the basket to let you pour that first cup mid-brew. Be aware that using this feature will weaken the flavor strength of the finished pot, because the flavor profile of coffee brewed at the beginning of the cycle differs from coffee made at the end.

NOTE: Removing carafe for more than 20 seconds may cause filter basket to overflow.

Wipe the area under the grinder basket with a damp cloth. If water gets into the grinder motor, the motor may become damaged and may malfunction.

Once clean, reverse the above steps. Remove the carafe from the warming plate. Discard any remaining coffee. The carafe and lid can be washed in warm soapy water and rinsed thoroughly, or placed in a dishwasher.

The carafe and carafe lid should be placed on the upper rack only. Do not use scouring agents or harsh cleansers on any part of the coffeemaker. Never immerse base unit in water or other liquid. To clean base, simply wipe with a clean, damp cloth and dry before storing.

Wipe warming plate with a clean, damp cloth. Never use rough, abrasive materials or cleansers to clean the warming plate. Do not dry the inside of the water reservoir with a cloth, as lint may remain.

***Note:** Reservoir lid can also be removed for easy cleaning. Open the lid 60° and gently pull toward you. To replace, reverse steps.

DECALCIFICATION

Decalcification refers to removing the calcium deposits which form over time on the metal parts of the coffeemaker.

For best performance from your coffeemaker, decalcify the base unit from time to time. The frequency depends upon the hardness of your tap water and how often you use the coffeemaker.

To clean, fill the water reservoir to capacity with a mixture of 1/3 white vinegar and 2/3 water. Turn the coffeemaker on by pressing the ON button. One cycle should be sufficient to adequately clean the coffeemaker. When the cycle is completed and five beeps sound, turn coffeemaker off. Repeat operation, this time using fresh cold water.

CLEANING AND MAINTENANCE

COMPLETELY CLEAN AND DRY ALL PARTS AFTER EVERY USE

Always turn coffeemaker OFF and remove the plug from the electrical outlet before cleaning.

Open the reservoir lid*. Remove the grinder basket lid by using the recessed area on each side of the lid. Then remove grinder basket. Open filter basket door. Remove filter basket cover and filter basket. The grinder basket, grinder basket lid, filter basket and filter basket cover can be washed in warm soapy water and rinsed thoroughly, or cleaned in the upper rack of the dishwasher. Dry all parts after every use. Do not put any water in the unit once the grinder basket has been removed.

WARRANTY

LIMITED THREE-YEAR WARRANTY

This warranty is available to consumers only. You are a consumer if you own a Cuisinart® Grind & Brew 12-Cup Automatic™ Coffeemaker that was purchased at retail for personal, family or household use. Except as otherwise required under applicable law, this warranty is not available to retailers or other commercial purchasers or owners.

We warrant that your Cuisinart® Grind & Brew 12-Cup Automatic™ Coffeemaker will be free of defects in materials and workmanship under normal home use for 3 years from the date of original purchase.

We suggest you complete and return the enclosed product registration card promptly to facilitate verification of the date of original purchase.

However, return of the product registration card does not eliminate the need for the consumer to maintain the original proof of purchase in order to obtain the warranty benefits. In the event that you do not have proof of purchase date, the purchase date for purposes of this warranty will be the date of manufacture.

If your Cuisinart® Grind & Brew 12-Cup Automatic™ Coffeemaker should prove to be defective within the warranty period, we will repair it, or if we think necessary, replace it. To obtain warranty service, simply call our toll-free number 1-800-726-0190 for additional information from our Customer Service Representatives, or send the defective product to Customer Service at Cuisinart, 150 Milford Road, East Windsor, NJ 08520.

To facilitate the speed and accuracy of your return, please enclose \$10.00 for shipping and handling of the product.

Please pay by check or money order (California residents need only supply proof of purchase and should call 1-800-726-0190 for shipping instructions).

NOTE: For added protection and secure handling of any Cuisinart® product that is being returned, we recommend you use a traceable, insured delivery service. Cuisinart cannot be held responsible for in-transit damage or for packages that are not delivered to us. Lost and/or damaged products are not covered under warranty. Please be sure to include your return address, daytime phone number, description of the product defect, product model number (located on bottom of product), original date of purchase, and any other information pertinent to the product's return.

Your Cuisinart® Grind & Brew 12-Cup Automatic™ Coffeemaker has been manufactured to the strictest specifications and has been designed for use with the authorized accessories and replacement parts.

This warranty expressly excludes any defects or damages caused by accessories, replacement parts, or repair service other than those that have been authorized by Cuisinart.

This warranty does not cover any damage caused by accident, misuse, shipment or other ordinary household use.

This warranty excludes all incidental or consequential damages. Some states do not allow the exclusion or limitation of these damages, so they may not apply to you.

CALIFORNIA RESIDENTS ONLY

California law provides that for In-Warranty Service, California residents have the option of returning a nonconforming product (A) to the store where it was purchased or (B) to another retail store which sells Cuisinart products of the same type.

The retail store shall then, at its discretion, either repair the product, refer the consumer to an independent repair facility, replace the product, or refund the purchase price less the amount directly attributable to the consumer's prior usage of the product. If the above two options do not result in the appropriate relief to the consumer, the consumer may then take the product to an independent repair facility if service or repair can be economically accomplished. Cuisinart and not the consumer will be responsible for the reasonable cost of such service, repair, replacement, or refund for nonconforming products under warranty.

California residents may also, according to their preference, return nonconforming products directly to Cuisinart for repair, or if necessary, replacement, by calling our Consumer Service Center toll-free at 1-800-726-0190.

Cuisinart will be responsible for the cost of the repair, replacement, and shipping and handling for such products under warranty.

BEFORE RETURNING YOUR CUISINART PRODUCT

If you are experiencing problems with your Cuisinart® product, we suggest that you call our Cuisinart® Service Center at 1-800-726-0190 before returning the product serviced. If servicing is needed, a representative can confirm whether the product is under warranty and direct you to the nearest service location.

Important: If the nonconforming product is to be serviced by someone other than Cuisinart's Authorized Service Center, please remind the servicer to call our Consumer Service Center at 1-800-726-0190 to ensure that the problem is properly diagnosed, the product serviced with the correct parts, and the product is still under warranty.

Cuisinart®

SAVOR THE GOOD LIFE®



Coffeemakers



Food Processors



Toasters



Blenders



Cookware



Ice Cream Makers

Cuisinart offers an extensive assortment of top quality products to make life in the kitchen easier than ever. Try some of our other countertop appliances and cookware, and Savor the Good Life®.

www.cuisinart.com

©2010 Cuisinart
Cuisinart® is a registered
trademark of Cuisinart

Any trademarks or service marks of third parties used herein are the trademarks or service marks of their respective owners.

150 Milford Road
East Windsor, NJ 08520
Printed in China

08CU224

IB-8338A